





-  ETC Source4 19deg @ 575w
-  ETC 26° Source-4 @ 575w
-  ETC Source-4 36° @ 575w
-  Altman Ground Cyc 4 Cells @ 4X1kw
-  USITT PAR64-MFL @ 1kw

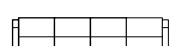

NOTES

Scale: NTS
 Date: 10/30/2022
 Version:
 Drawn By:

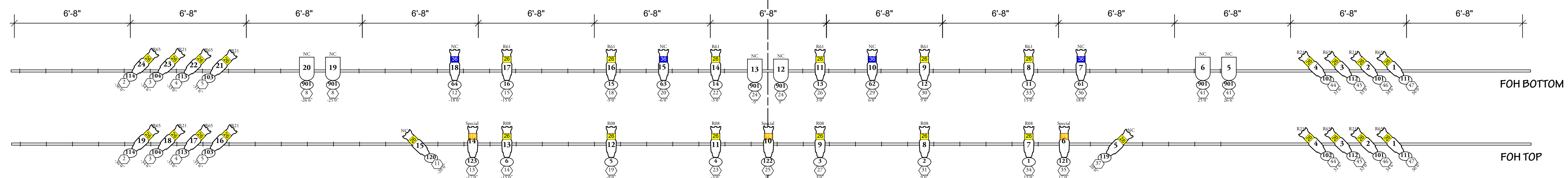
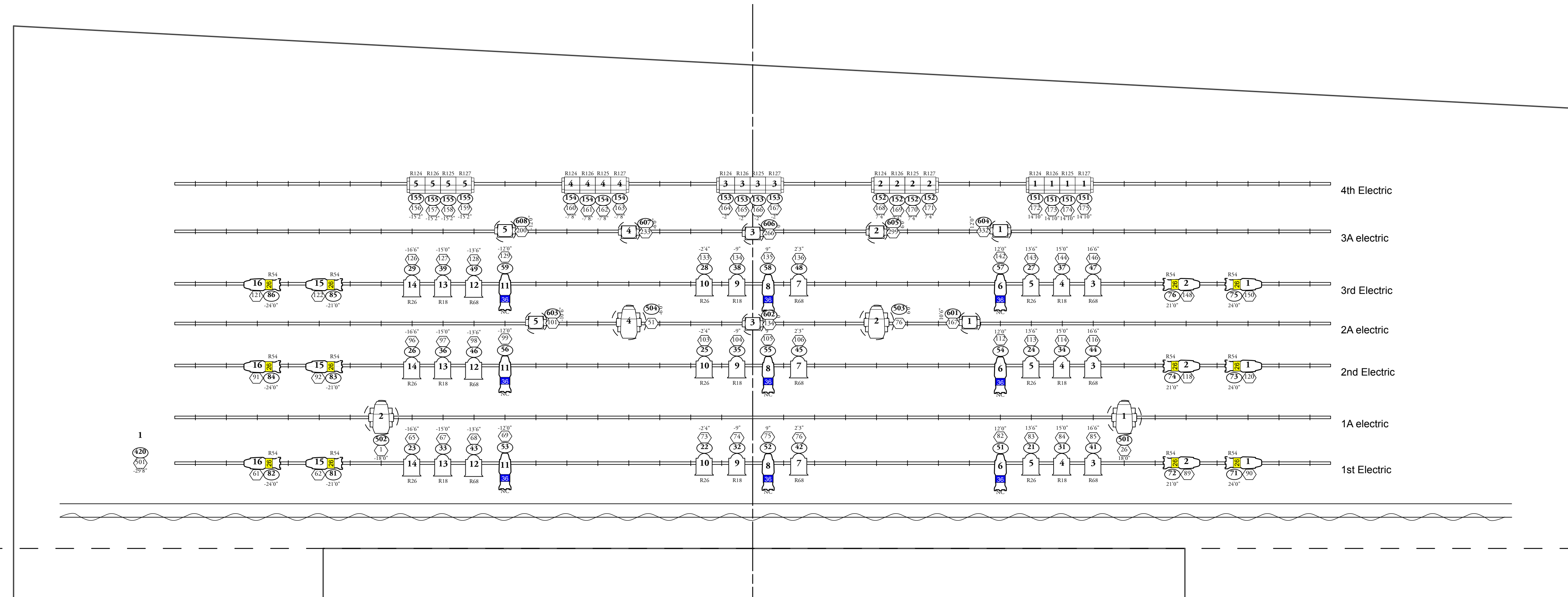
Plate#
1 of 2